

ALL DIMENSIONS ARE IN MM UNLESS STATED. ASK IF ANY DOUBT. NO SHARP CORNERS A3

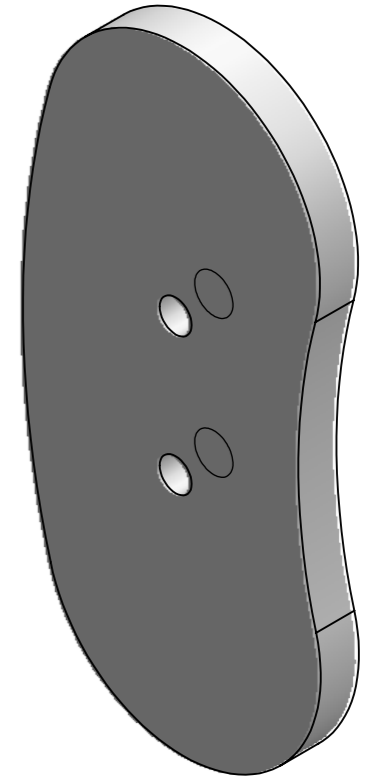
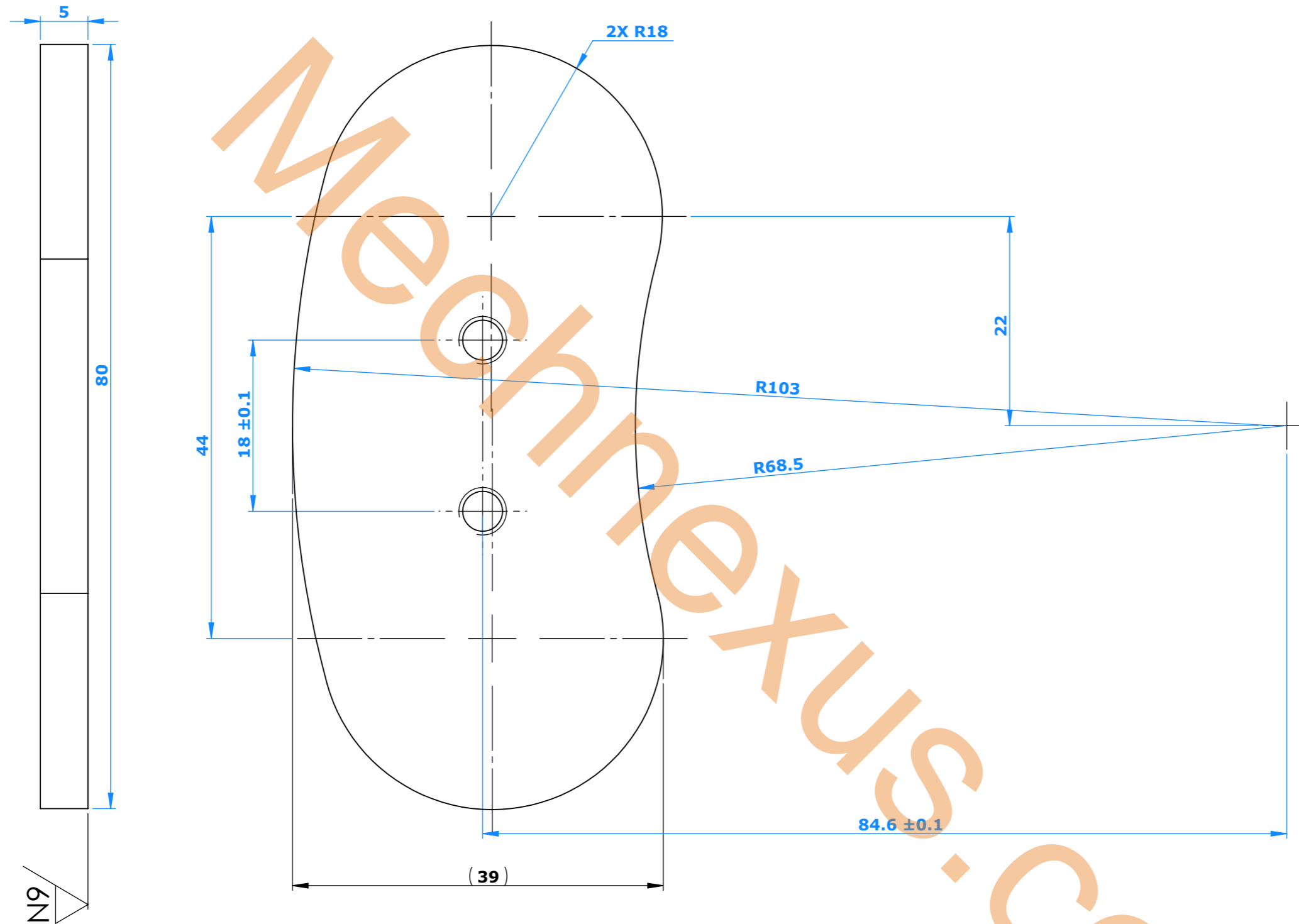

NOTE :
 ALL MACHINED PART SHOULD BE BURR FREE
 ALL UNSPECIFIED CHAMFER 1 X 45° AND FILLET 0.5mm

Dim.	Nominal Tolerance								Sym	Surface Roughness Symbol					
	Over	6	30	120	400	1000	2000	4000		N12	N11	N9	N7	N6	N3
Tolerance	± 0.1	± 0.2	± 0.3	± 0.5	± 0.8	± 1.2	± 2	Val. µRa	50	25	6.3	1.6	0.8	0.1	

Sr/No.		Description		Rev.	Name	Date:	QTY:	Raw Weight:	Finish Weight:	Heat Treatment / Surface Coating
Scale: NTS		Name		Date:		Raw Material Size				
Drawn		Name		Date:		Material Designation				
Checked		Name		Date:		Higher Assly No				
Approved		Name		Date:		Assly No				
Assly/Part Description: OPENING COVER							Assly/Part No:			
Sheet No.							1 OF 1			

THIS DOCUMENT/DRAWING IS PROPERTY OF MECHNEXUS.COM AND MUST NOT BE COPIED OR MODIFIED IN ANY UNDER CIRCUMSTANCES UNLESS WITHOUT WRITTEN PERMISSION.