

ALL DIMENSIONS ARE IN MM UNLESS STATED. ASK IF ANY DOUBT. NO SHARP CORNERS A3

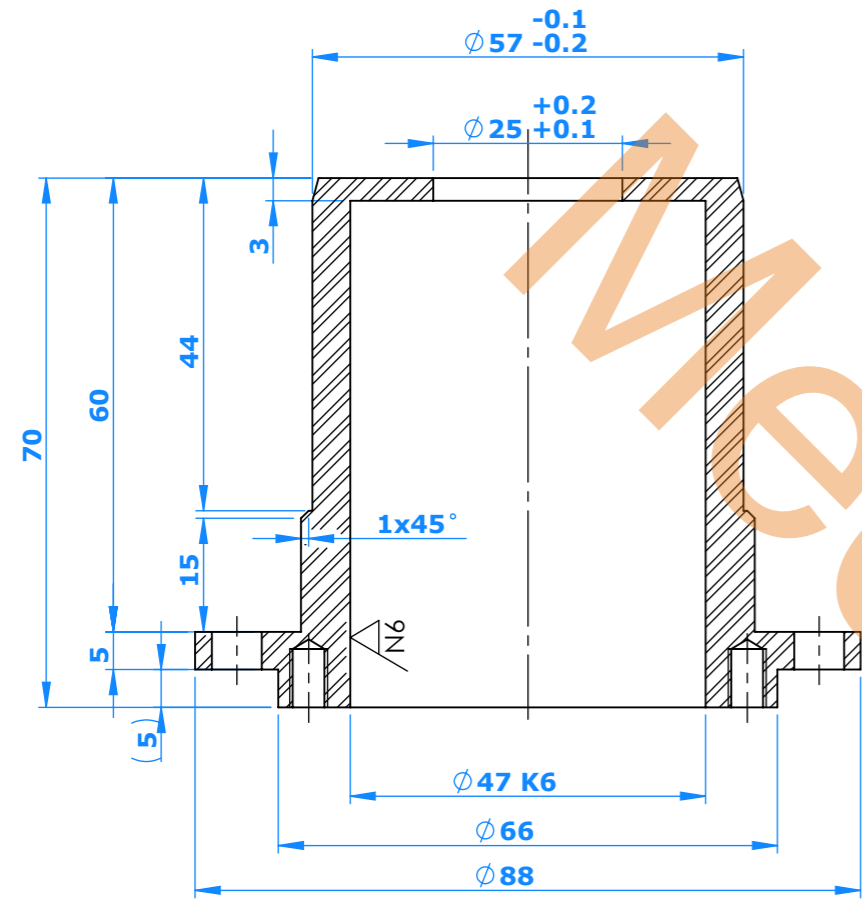

SECTION A-A

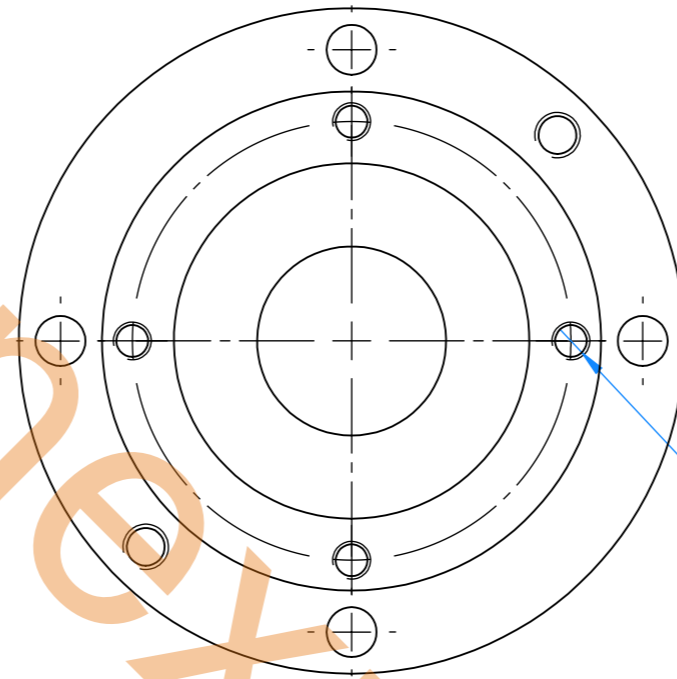

4 x ϕ 4.20 ∇ 9.00
M5 - 6H ∇ 8 PCD ϕ 52 Equi Spaced

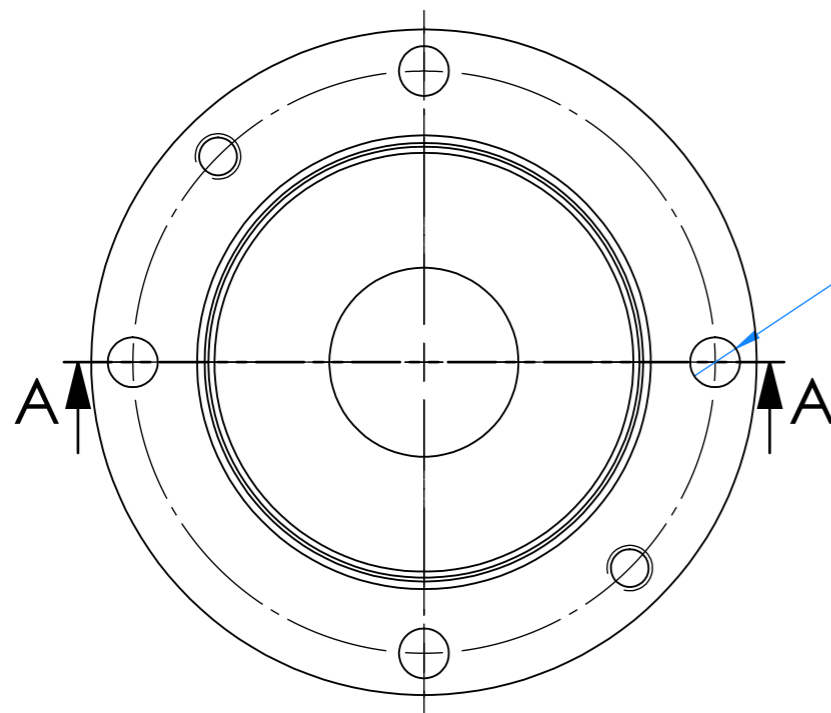
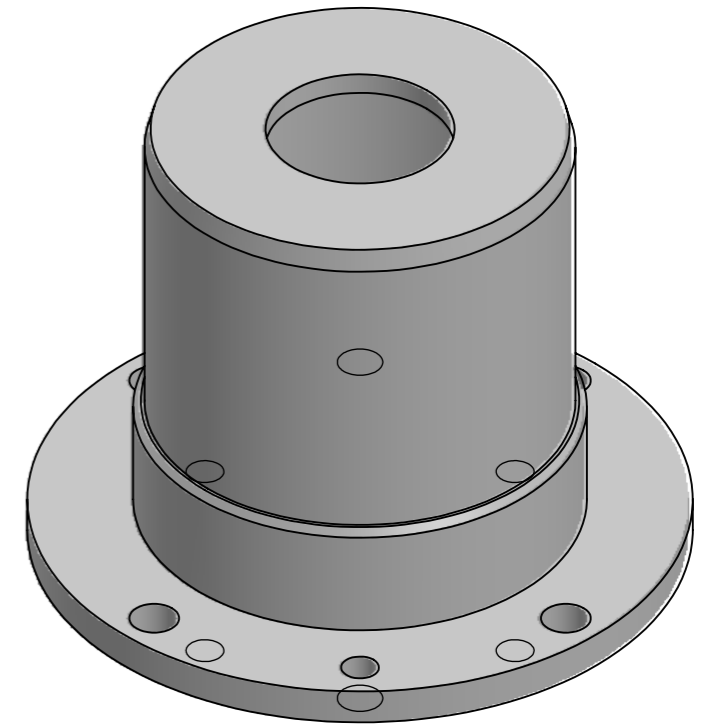

4 x ϕ 7 Thru. PCD ϕ 69 Equi Spaced

Sr/No.	Description	Rev.	Name	Date:	QTY:	Raw Weight:	Finish Weight:	Heat Treatment / Surface Coating
Scale: NTS Name: _____ Date: _____ Drawn: _____ Checked: _____ Approved: _____					Raw Material Size			
					Material Designation			
					Higher Assly No			
Assly/Part Description:					Assly/Part No:			
BEARING CASING					Sheet No. 1 OF 2			

Dim.	Nominal Tolerance								Sym	Surface Roughness Symbol					
	Over Upto & Inc.	-	6	30	120	400	1000	2000		N12	N11	N9	N7	N6	N3
Tolerance	± 0.1	± 0.2	± 0.3	± 0.5	± 0.8	± 1.2	± 2	Val. μ Ra	50	25	6.3	1.6	0.8	0.1	