

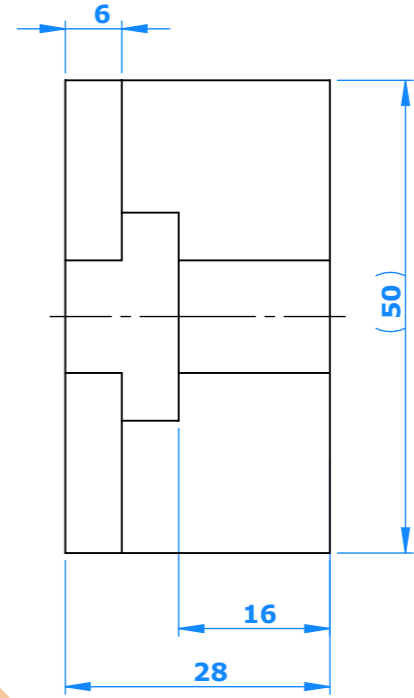

ALL DIMENSIONS ARE IN MM UNLESS STATED. ASK IF ANY DOUBT. NO SHARP CORNERS A3

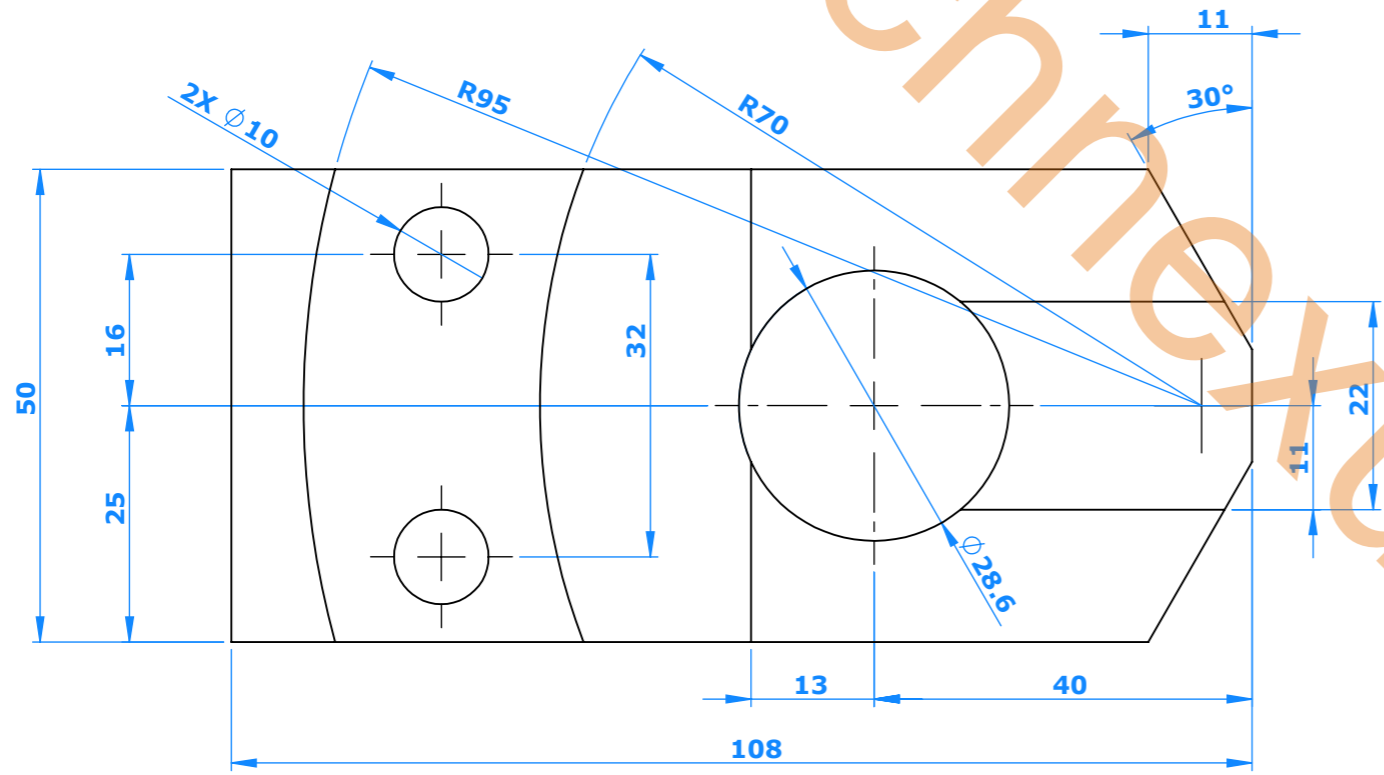
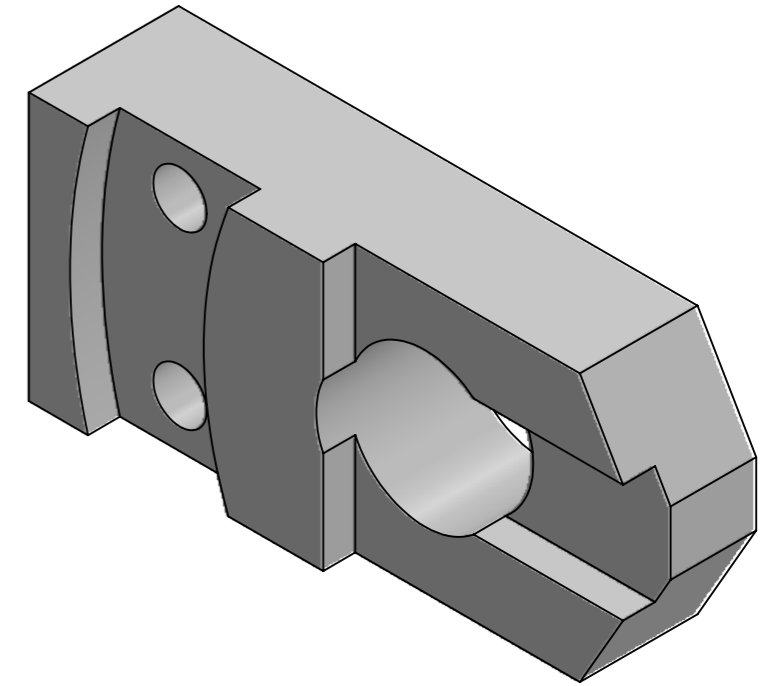
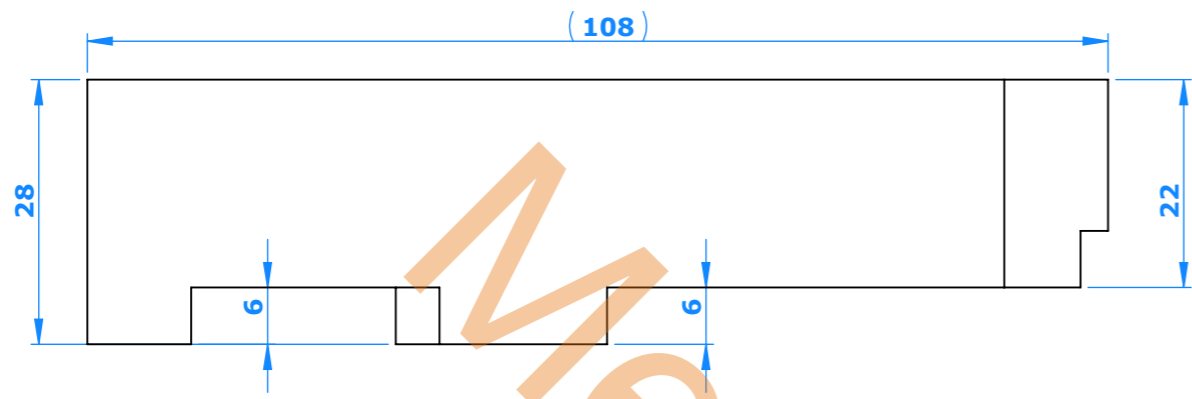

Sr/No.		Description		Rev.	Name	Date:	QTY:	Raw Weight:	Finish Weight:	Heat Treatment / Surface Coating
Scale: NTS		Name		Date:		Raw Material Size				
Drawn						Material Designation				
Checked						Higher Assly No				
Approved						Assly/Part Description:		Assly/Part No:		
		Index Slide		Sheet No. 1 OF 1						

Dim.	Nominal Tolerance								Sym	Surface Roughness Symbol					
	Over Upto & Inc.	-	6	30	120	400	1000	2000		N12	N11	N9	N7	N6	N3
Tolerance	± 0.1	± 0.2	± 0.3	± 0.5	± 0.8	± 1.2	± 2	Val. μRa	50	25	6.3	1.6	0.8	0.1	

THIS DOCUMENT/DRAWING IS PROPERTY OF MECHNEXUS.COM AND MUST NOT BE COPIED OR MODIFIED IN ANY UNDER CIRCUMSTANCES UNLESS WITHOUT WRITTEN PERMISSION.