

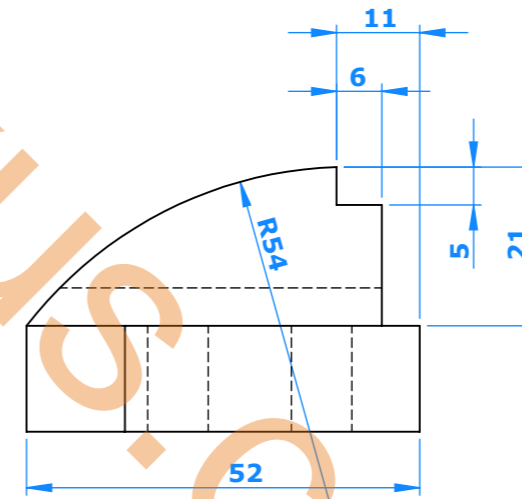

ALL DIMENSIONS ARE IN MM UNLESS STATED. ASK IF ANY DOUBT. NO SHARP CORNERS A3

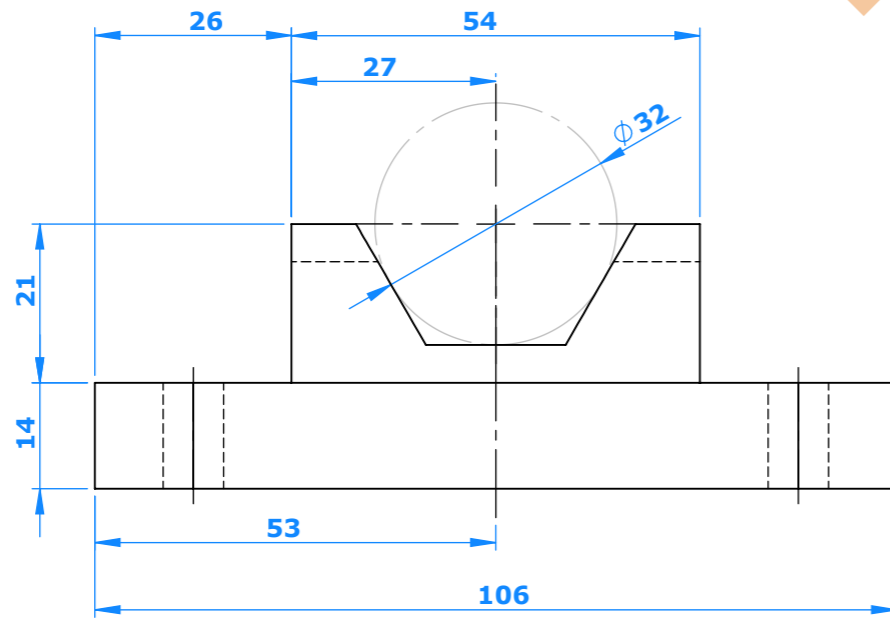
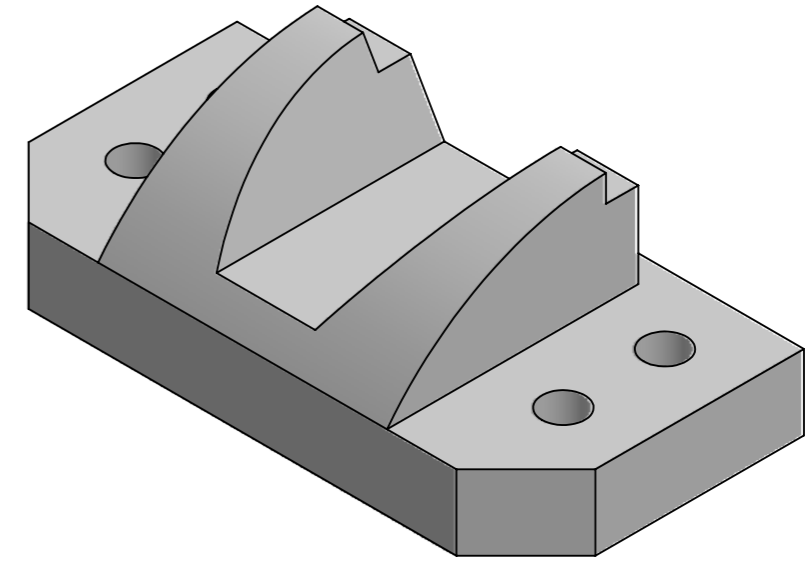
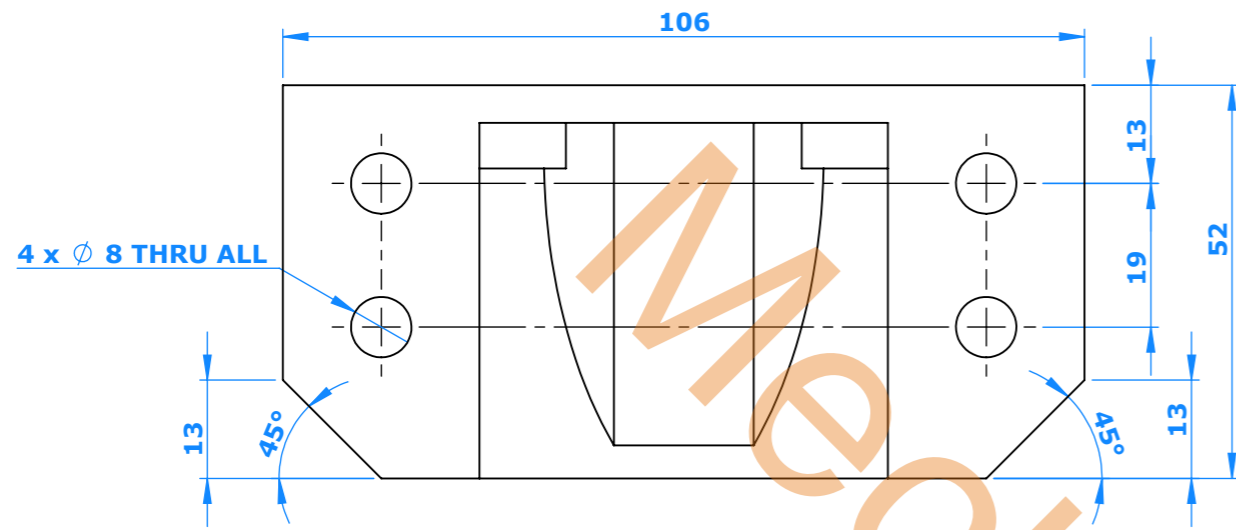

				QTY:	Raw Weight:	Finish Weight:	Heat Treatment / Surface Coating
Sr/No.	Description	Rev.	Name	Date:			
Scale: NTS				Name	Date:	Raw Material Size	
				Drawn		Material Designation	
				Checked		Higher Assly No	
				Approved			
Assly/Part Description:					Assly/Part No:		
<b>Locating Finger</b>					Sheet No. 1 OF 1		

Dim.	Nominal Tolerance								Sym	Tolerance As Per Std. M/Cg Deviation For Open Dimensions as per ISO 2768					
	Over Upto & Inc.	6	30	120	400	1000	2000	4000		N12	N11	N9	N7	N6	N3
Tolerance	± 0.1	± 0.2	± 0.3	± 0.5	± 0.8	± 1.2	± 2	Val. µRa	50	25	6.3	1.6	0.8	0.1	

THIS DOCUMENT/DRAWING IS PROPERTY OF MECHNEXUS.COM AND MUST NOT BE COPIED OR MODIFIED IN ANY UNDER CIRCUMSTANCES UNLESS WITHOUT WRITTEN PERMISSION.