

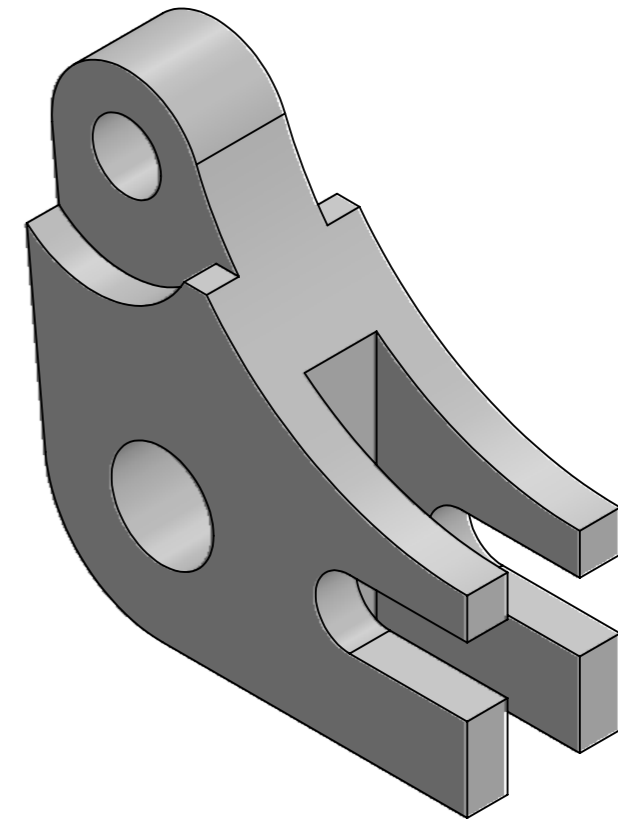

ALL DIMENSIONS ARE IN MM UNLESS STATED. ASK IF ANY DOUBT. NO SHARP CORNERS A3

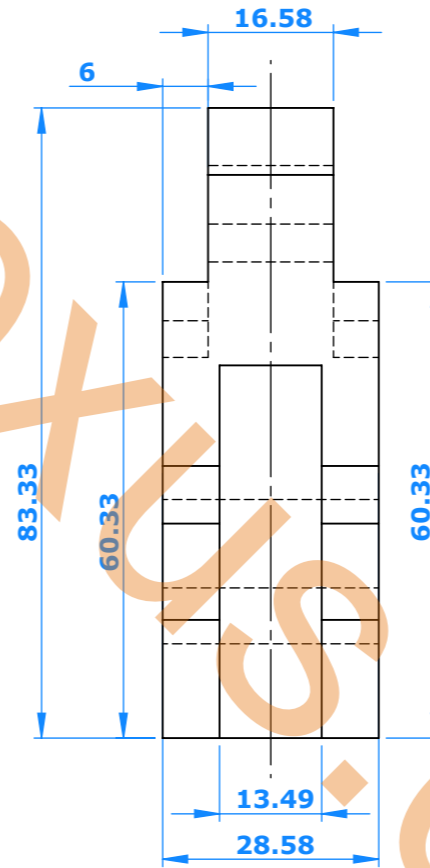
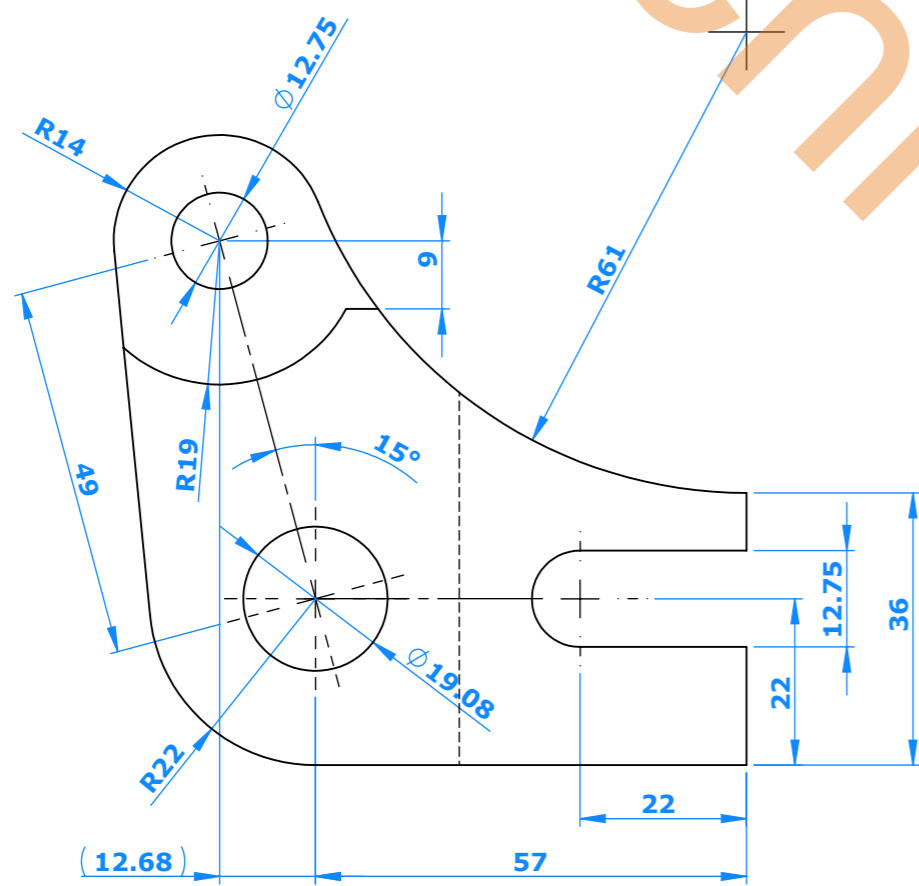
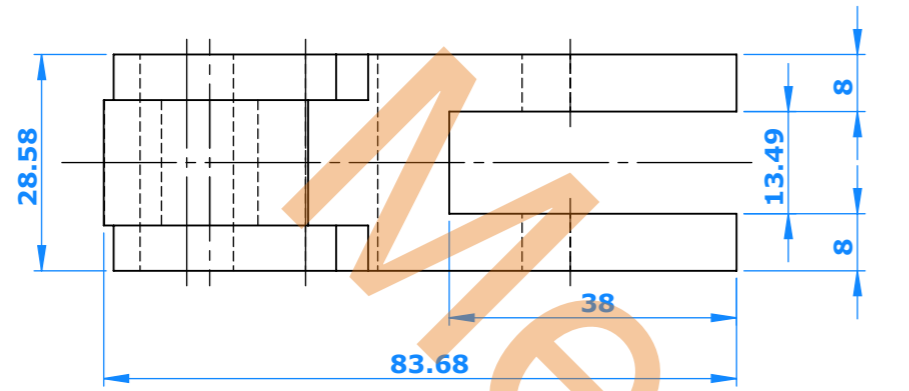

				QTY:	Raw Weight:	Finish Weight:	Heat Treatment / Surface Coating
Sr/No.	Description	Rev.	Name	Date:	Raw Material Size		
	Scale: NTS		Name	Date:	Material Designation		
	Drawn				Higher Assly No		
	Checked				Assly/Part Description:		
	Approved				Assly/Part No:		
				Toggle Lever		Sheet No. 1 OF 1	

Dim.	Nominal Tolerance								Sym	Surface Roughness Symbol					
	Over Upto & Inc.	6	30	120	400	1000	2000	4000		N12	N11	N9	N7	N6	N3
Tolerance	± 0.1	± 0.2	± 0.3	± 0.5	± 0.8	± 1.2	± 2		50	25	6.3	1.6	0.8	0.1	

THIS DOCUMENT/DRAWING IS PROPERTY OF MECHNEXUS.COM AND MUST NOT BE COPIED OR MODIFIED IN ANY UNDER CIRCUMSTANCES UNLESS WITHOUT WRITTEN PERMISSION.