

ALL DIMENSIONS ARE IN MM UNLESS STATED. ASK IF ANY DOUBT. NO SHARP CORNERS A3

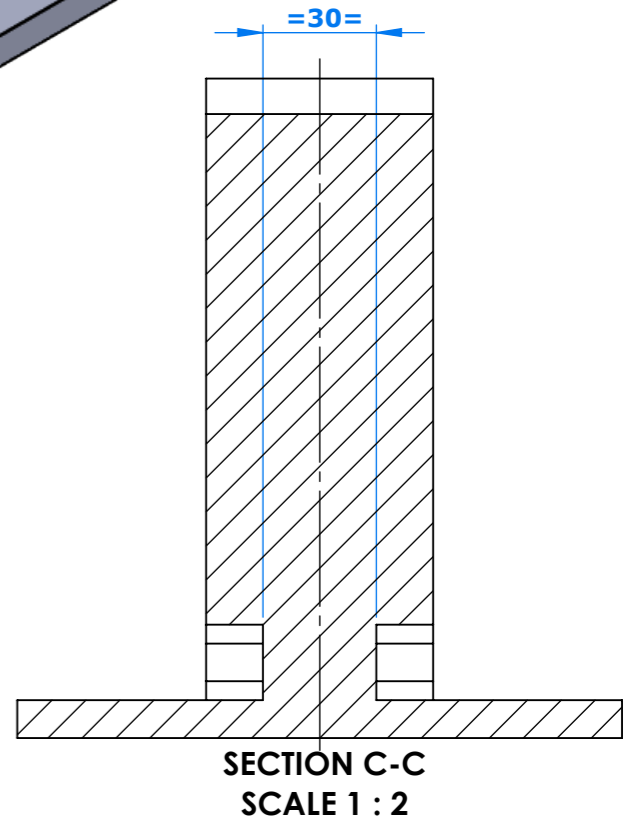

Sr/No.		Description		Rev.	Name	Date:	QTY:	Raw Weight:	Finish Weight:	Heat Treatment / Surface Coating
Scale: NTS		Name		Date:		Raw Material Size				
Drawn		Checked		Approved		Material Designation				
Assly/Part Description:		Assly/Part No:		Sheet No.		1 OF 1				
<b>Support</b>										

Nominal Tolerance		Tolerance As Per Std.							Surface Roughness Symbol							
M/Cg Deviation For Open Dimensions as per ISO 2768									Sym	N12	N11	N9	N7	N6	N3	
Dim.	Over Upto & Inc.	-	6	30	120	400	1000	2000								Val. µRa
	Tolerance	± 0.1	± 0.2	± 0.3	± 0.5	± 0.8	± 1.2	± 2								

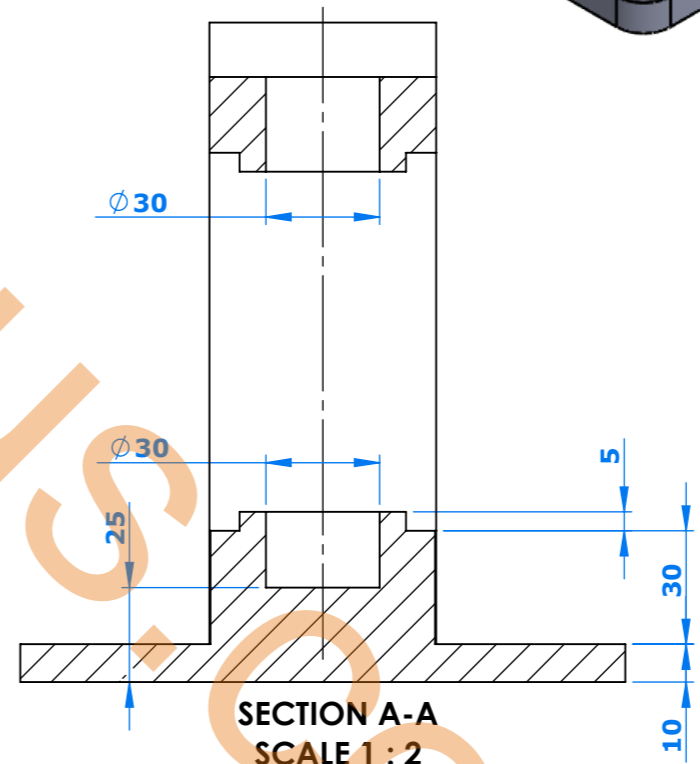
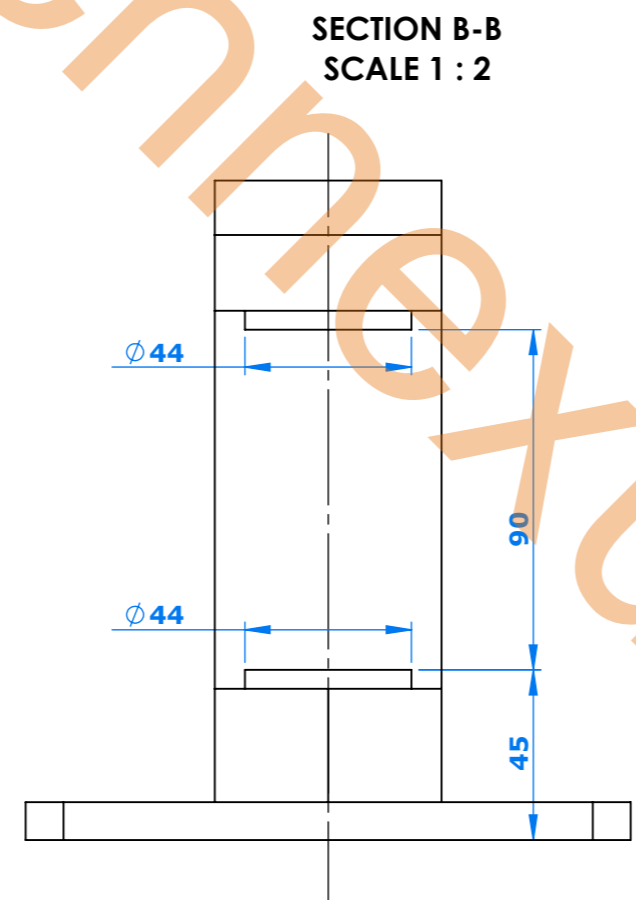
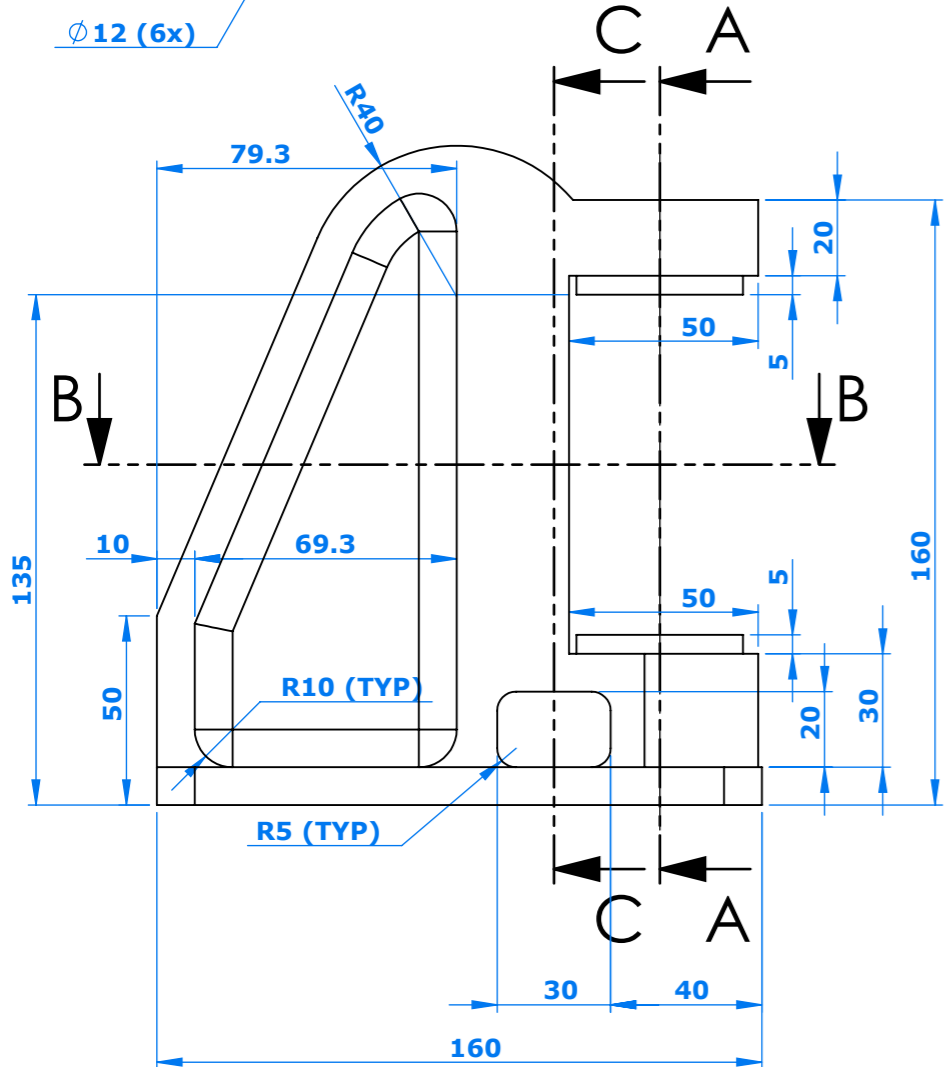
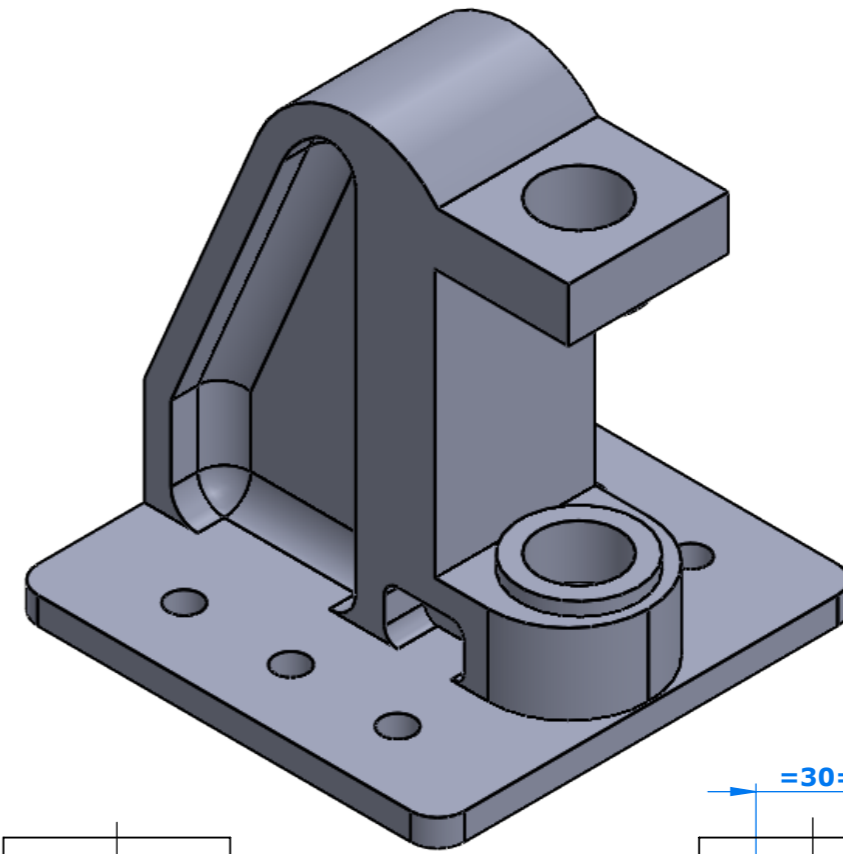
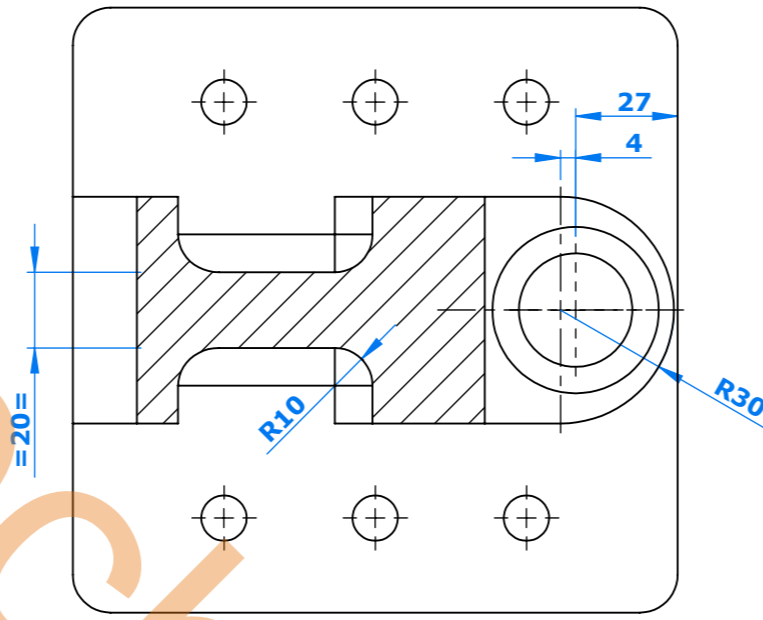
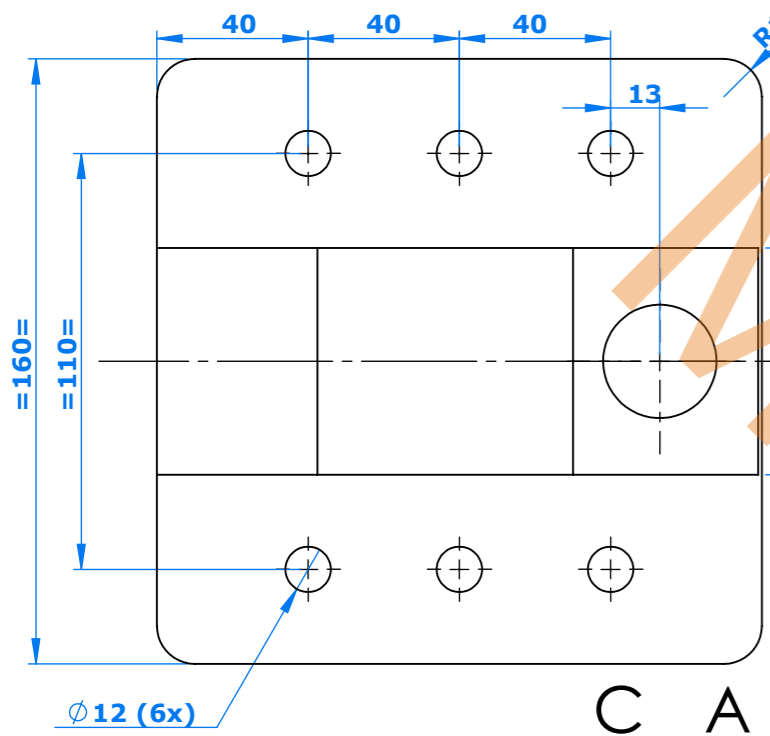

THIS DOCUMENT/DRAWING IS PROPERTY OF MECHNEXUS.COM AND MUST NOT BE COPIED OR MODIFIED IN ANY UNDER CIRCUMSTANCES UNLESS WITHOUT WRITTEN PERMISSION.