

ALL DIMENSIONS ARE IN MM UNLESS STATED. ASK IF ANY DOUBT. NO SHARP CORNERS A3

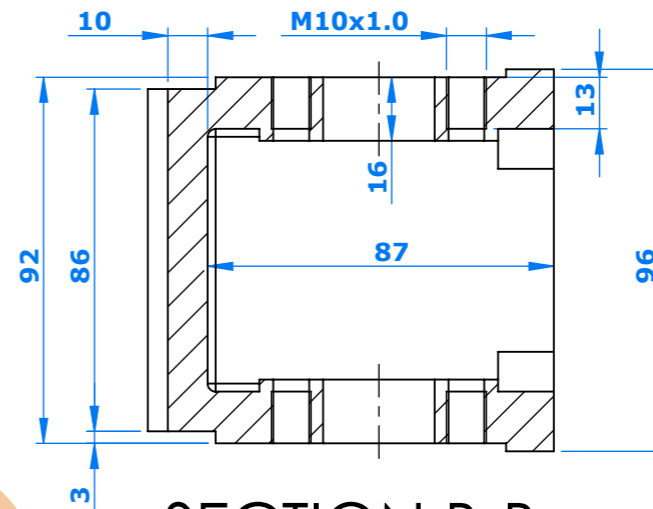

SECTION B-B
SCALE 1 : 1.9

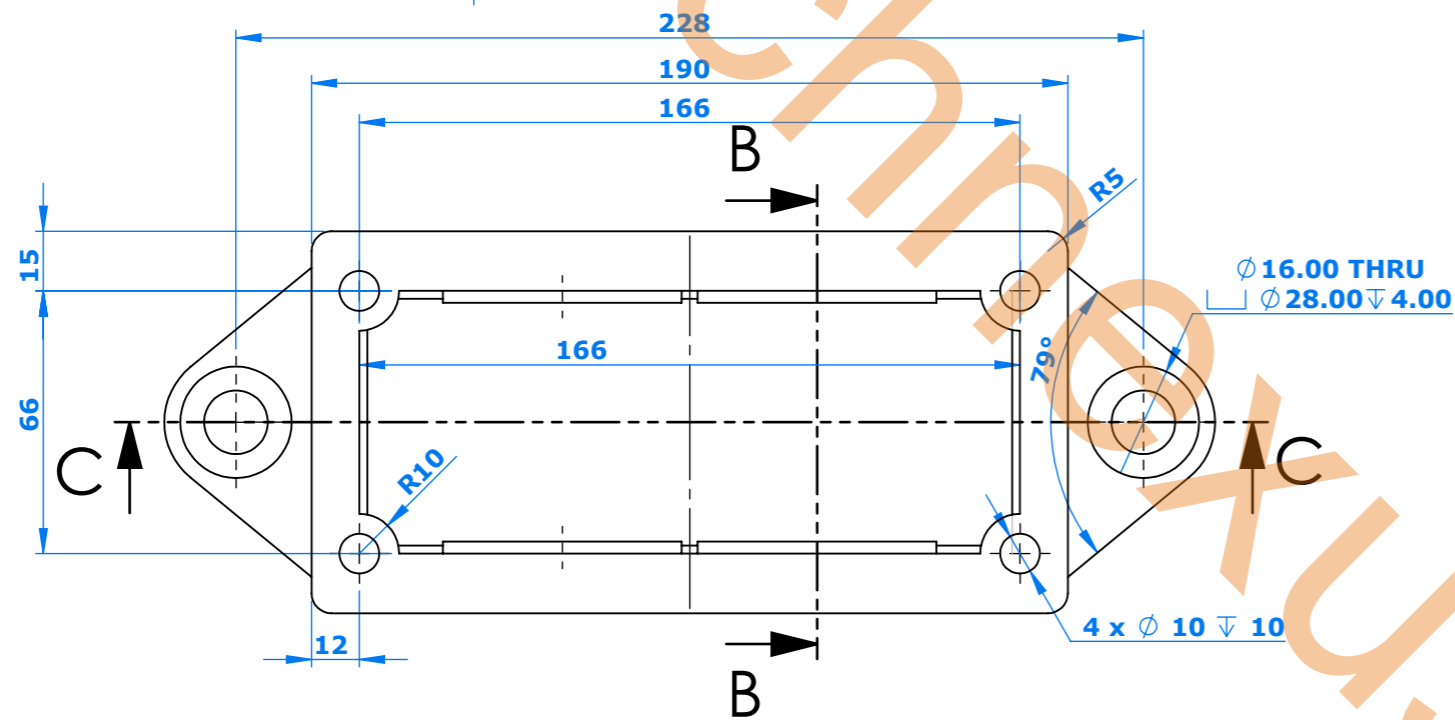
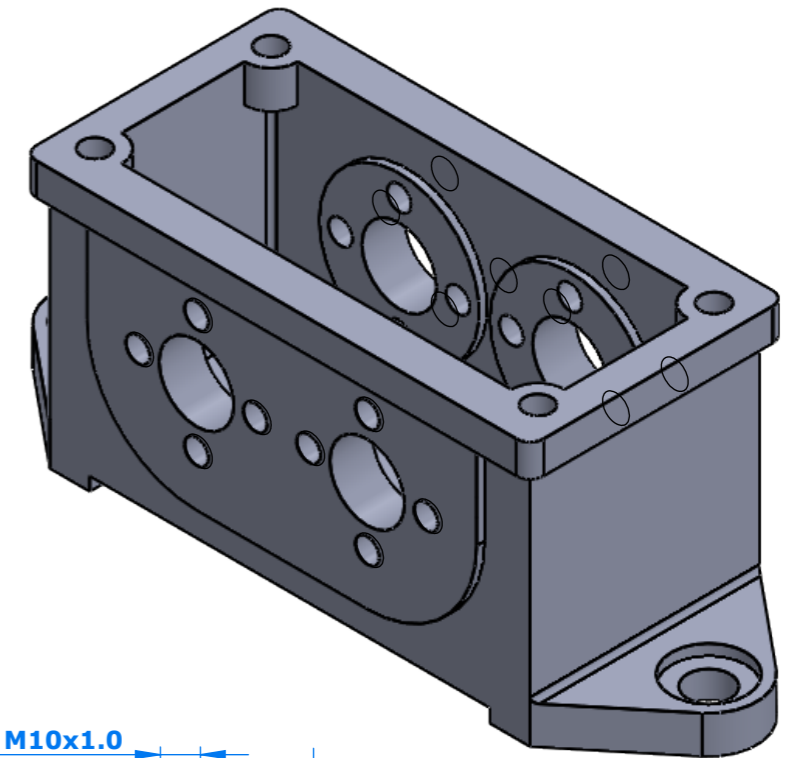
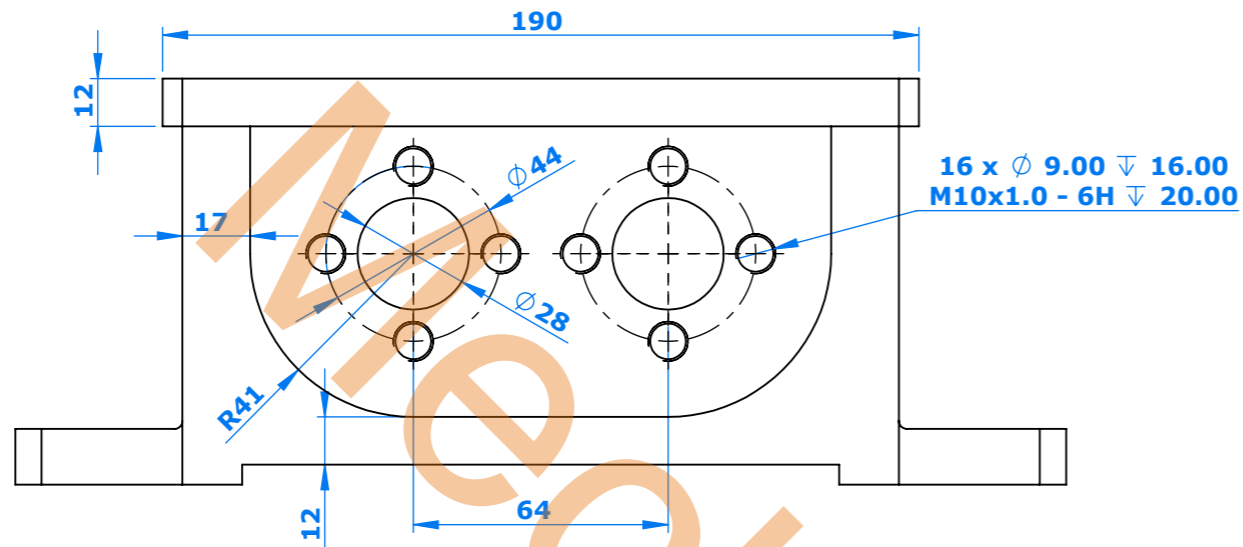
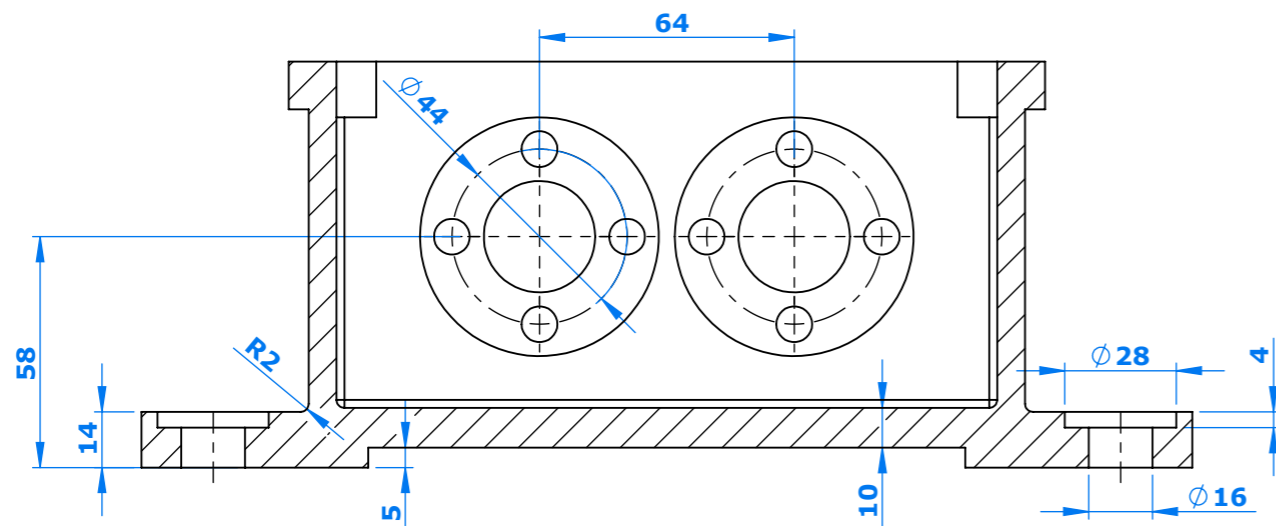

SECTION C-C

| | | | | | | | | | | | | | | | | | | | | | |
|-------------------------|--|--|--|-------------|--|--|--|------|--|------|--|----------------|--|----------------------|--|-------------|--|----------------|--|----------------------------------|--|
| Sr/No. | | | | Description | | | | Rev. | | Name | | Date: | | QTY: | | Raw Weight: | | Finish Weight: | | Heat Treatment / Surface Coating | |
| | | | | Scale: NTS | | | | | | Name | | Date: | | 1 | | | | | | | |
| | | | | Drawn | | | | | | | | | | Raw Material Size | | | | | | | |
| | | | | Checked | | | | | | | | | | Material Designation | | | | | | | |
| | | | | Approved | | | | | | | | | | Higher Assly No | | | | | | | |
| Assly/Part Description: | | | | | | | | | | | | Assly/Part No: | | | | | | | | | |
| Housing | | | | | | | | | | | | | | | | | | | | | |
| Sheet No. | | | | | | | | | | | | 1 OF 1 | | | | | | | | | |



| Nominal Tolerance | | Tolerance As Per Std. | | | | | | | Sym | Surface Roughness Symbol | | | | | |
|-------------------|------------------|-----------------------|-----------|-----------|-----------|-----------|-----------|---------|---------------|--------------------------|-----|-----|-----|-----|-----|
| Dim. | Over Upto & Inc. | - | 6 | 30 | 120 | 400 | 1000 | 2000 | | N12 | N11 | N9 | N7 | N6 | N3 |
| | Tolerance | \pm 0.1 | \pm 0.2 | \pm 0.3 | \pm 0.5 | \pm 0.8 | \pm 1.2 | \pm 2 | Val. μ Ra | 50 | 25 | 6.3 | 1.6 | 0.8 | 0.1 |

THIS DOCUMENT/DRAWING IS PROPERTY OF MECHNEXUS.COM AND MUST NOT BE COPIED OR MODIFIED IN ANY UNDER CIRCUMSTANCES UNLESS WITHOUT WRITTEN PERMISSION.